

PM11 1/2" - 3"

600 WOG Soldered Ends

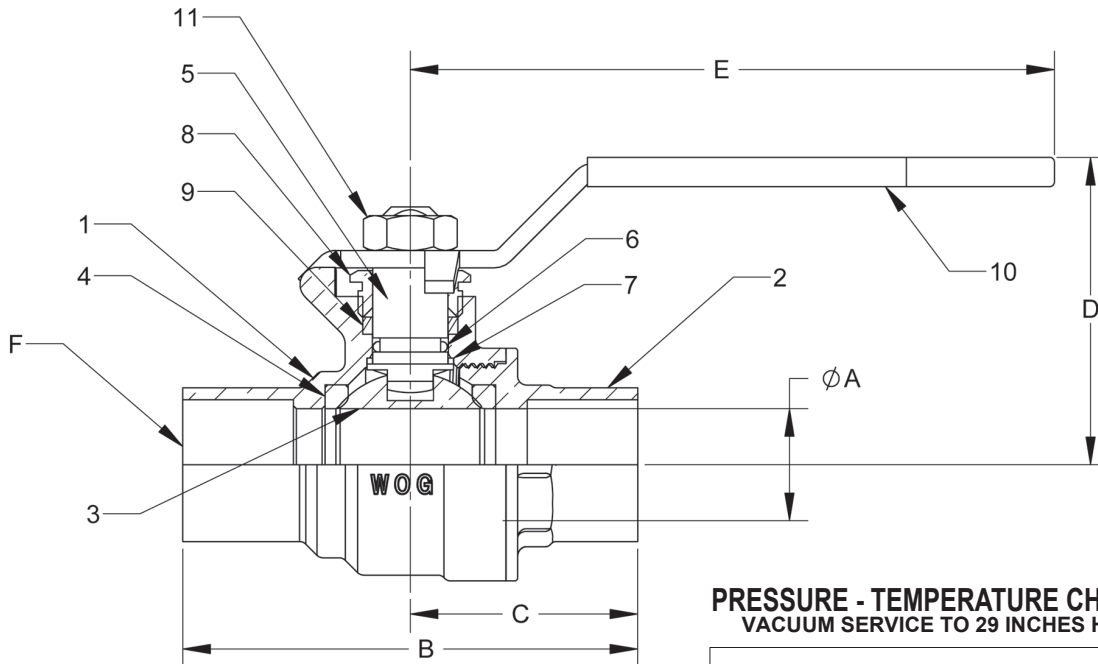

PRESSURE - TEMPERATURE CHART
VACUUM SERVICE TO 29 INCHES Hg.

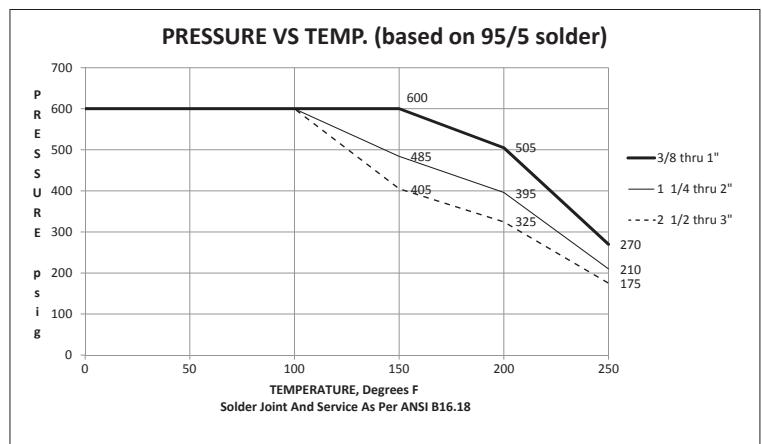

MATERIALS LIST

ITEM	PART	MATERIALS	ASTM/SPEC
1	Body	Brass, Forged	B283
2	Tailpiece	Brass, Forged	B283
3	Ball	CP Brass Ball	B283
4	Ball Seat	PTFE	Commercial
5	Stem	Brass	B124
6	O-Ring	Buna-N	D2006
7	Thrust Washer	PTFE	Commercial
8	Gland Nut	Brass	B124
9	Packing	PTFE	Commercial
10	Handle	Zinc Plated Steel	B633
11	Handle Nut	Zinc Plated Steel	B633

DIMENSIONS

Size		1/2" DN15	3/4" DN20	1" DN25	1-1/4" DN32	1-1/2" DN40	2" DN50	2-1/2" DN65	3" DN80
A PORT DIA	INCH mm	0.51 13	0.76 19	0.98 25	1.26 32	1.5 38	2.0 51	2.0 51	2.52 64
B	INCH mm	2.28 58	3.1 79	3.56 90	4.13 105	4.64 118	5.75 146	5.94 151	6.97 177
C	INCH mm	1.14 29	1.55 39	1.78 45	2.06 52	2.32 59	2.87 73	2.97 75	3.49 89
D	INCH mm	1.46 37	1.93 49	2.10 53	2.33 59	2.52 64	2.96 75	3.70 94	4.00 102
E	INCH mm	3.14 80	4.35 110	4.35 110	5.00 127	5.00 127	6.90 175	6.90 175	6.90 175
F TUBE DIA	SWEAT DN	0.63 15	0.88 20	1.13 25	1.38 32	1.63 40	2.13 50	2.63 65	3.13 80
Cv	GPM	18	40	72	112	161	287	287	448
TORQUE	INCH-LB N.m	19 2.1	58 6.5	69 7.8	89 10	124 14	210 24	201 23	488 55
WEIGHT	LBS. grams	0.40 180	0.82 370	1.15 521	1.53 696	2.23 1012	4.61 2092	5.48 2488	8.65 3927
CASE QTY	VALVES	120	60	48	24	24	8	8	6

Rev. 2

STANDARD PORT 400 WOG